



The output power of 5000 W fits into a servo motor EM3A-50 with a flange size 130 mm. This motor has low rotor inertia and high speed, suitable for highly dynamic systems. Movement accuracy is ensured by modern optical or magnetic encoders with a resolution of up to 23-bit. Products can be provided with a 24VDC holding brake option.

The EM3A series boasts a low inertia design for extremely-fast response times. These motors are highlighted with the perfect combination of compact size and high torque performance, ensuring unparalleled dynamic response and precision positioning when used together with servo drivers ED3L series. Versatile and powerful, these servo drive systems have a wide range of applications, thanks to its top-tier performance, varied power range, and compact form factor. Elevate your technical operations with the EM3A series servo motors and ED3L servo drive system.

Technical data

Output power	5000 W
Rated speed	3000 rpm
Maximum speed	5000 rpm
Rated torque	15.9 Nm
Maximum torque	47.7 Nm
Rated current	15.9 A
Maximum current	50 A
Motor inertia (motor without brake)	14 kg*cm ²

Technical data

Motor inertia (motor with brake)	15.4 kg*cm ²
Allowable radial shaft load	980 N
Allowable axial shaft load	392 N
Optional brake holding torque	≥20 Nm
Optional brake voltage	24 VDC
Weight (motor without brake)	15.5 kg
Weight (motor with brake)	17.5 kg
Flange	130 mm

Speed-torque curves

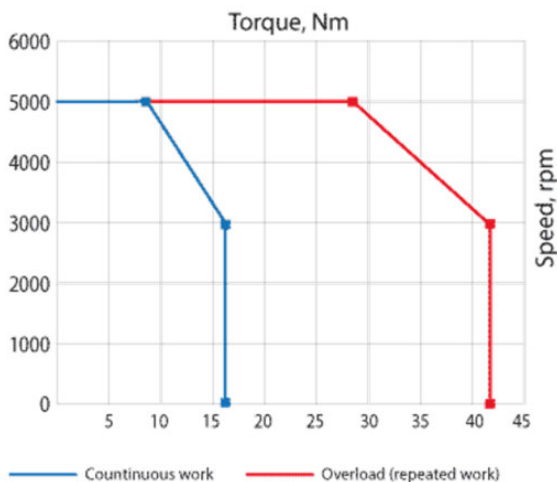

Available motor models

Motor model	Encoder	Brake	Servo drive	Input drive supply voltage
EM3A-50DLA224	absolute optic encoder, resolution 23-bit (8 388 608 ppr)	-	ED3L-50DMA ED3L-50DEA ED3L-50DPA	Three phase AC 380V...440V
EM3A-50DLA244		✓		
EM3A-50DTA244	absolute magnetic encoder, resolution 17-bit (131 072 ppr)	-		
EM3A-50DTA244		✓		

Dimensions of AC servo motor EM3A-50

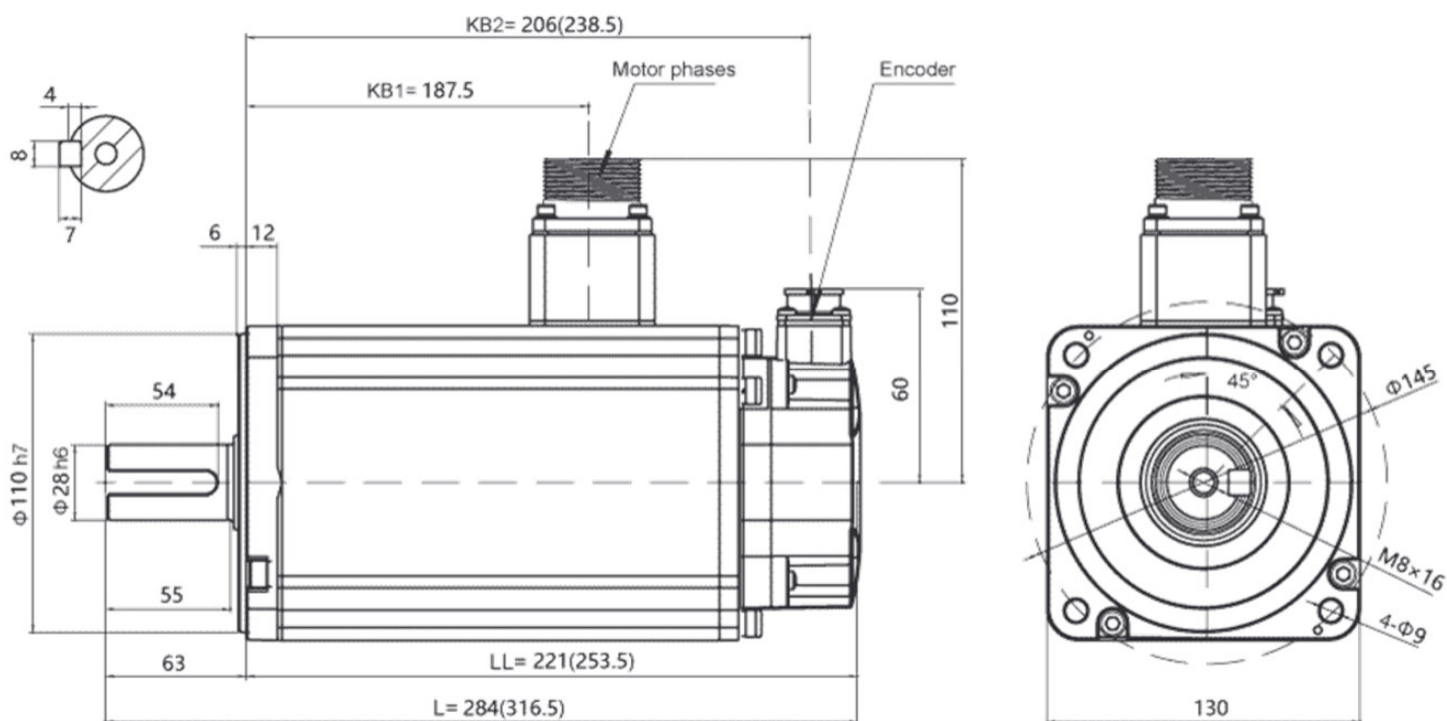

Note: The values in parentheses represent the values of motors with brakes

