



High-torque AC synchronous servo motor EM3L-40 is specially designed to provide low speed motion with increased force at the motor shaft. The motor is supplied with high resolution 23-bit optical or 17-bit magnetic absolute encoder. Optional 24VDC brake is available.

## Technical data

Output power	4000 W
Rated speed	1000 rpm
Maximum speed	1500 rpm
Rated torque	38.2 Nm
Maximum torque	120 Nm
Rated current	10.9 A
Motor inertia (motor without brake)	116.8 kg*cm <sup>2</sup>
Motor inertia (motor with brake)	123 kg*cm <sup>2</sup>

## Technical data

Allowable radial shaft load	1764 N
Allowable axial shaft load	588 N
Optional brake holding torque	≥72 Nm
Optional brake voltage	24 VDC
Weight (motor without brake)	29 kg
Weight (motor with brake)	33.6 kg
Flange	180 mm

## Speed-torque curves

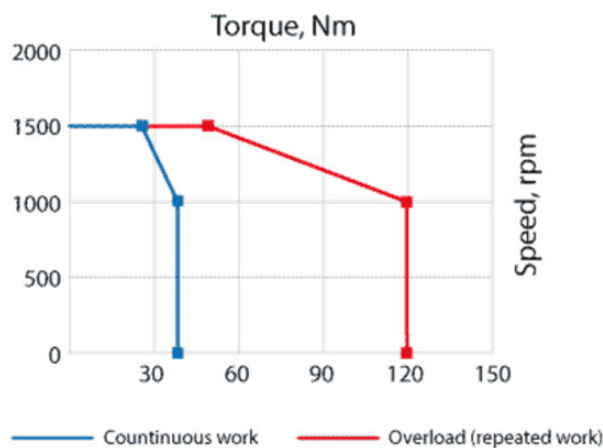

## Available motor models

Motor model	Encoder	Brake	Servo drive	Input drive supply voltage
EM3L-40DLA224	absolute optic encoder, resolution 23-bit (8 388 608 ppr)	-	ED3L-50DMA ED3L-50DEA ED3L-50DPA	Three phase AC 380V...440V
EM3L-40DLA244		✓		
EM3L-40DTA224	absolute magnetic encoder, resolution 17-bit (131 072 ppr)	-		
EM3L-40DTA244		✓		

## Dimensions of AC servo motor EM3L-40

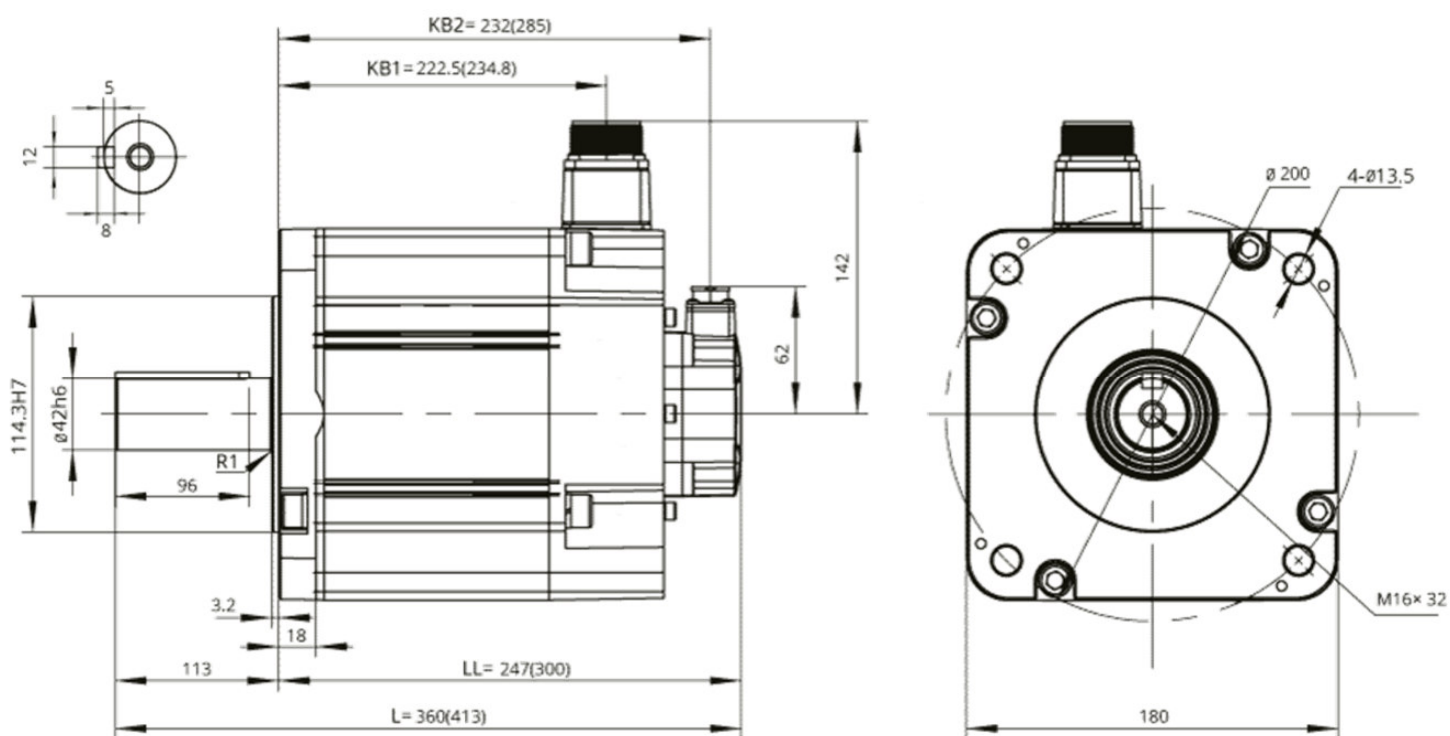

Note: The values in parentheses represent the values of motors with brakes

