

BMSD-20Modbus

DC BRUSH MOTOR CONTROLLER



BMSD-20Modbus is a programmable DC brush motor controller, which is intended for speed and position control. The programming function makes it possible to compose and upload user programs to the non-volatile memory of the device.

The controllers operate as a standalone device according to a pre-programmed algorithm or as a slave in a RS-485 network.

The current limiting function protects motors from overloads.

Technical parameters

Rated current in motor phase	20 A
Phase current limitation	1 – 20 A
Short-circuit protection	30 A
Power supply	12 – 24 VDC
Communication	RS-485 Modbus ASCII/RTU

Inputs for external discrete signals

- IN1, IN2 – programmable inputs, can be used as START/STOP and DIR signals or as discrete inputs in a user program. These inputs can be used as per the signal level or per a front edge of the signal.
- HARD STOP – emergency stop signal
- HA, HB – inputs for encoder signals for positioning and speed stabilization functions

Operation modes

- Program control – motion according to a user program
- Modbus speed control; speed stabilization is available for motors with encoder
- Position control for motors with encoder

Dimensions

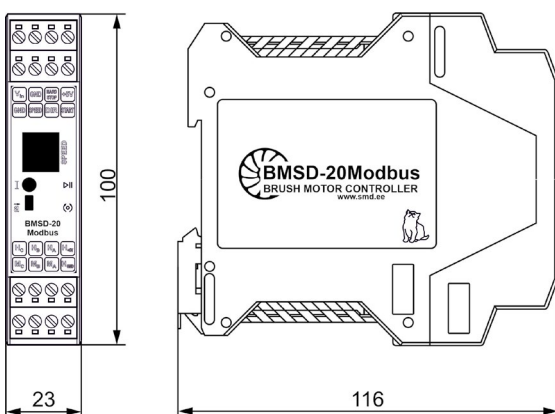

Software for the controller

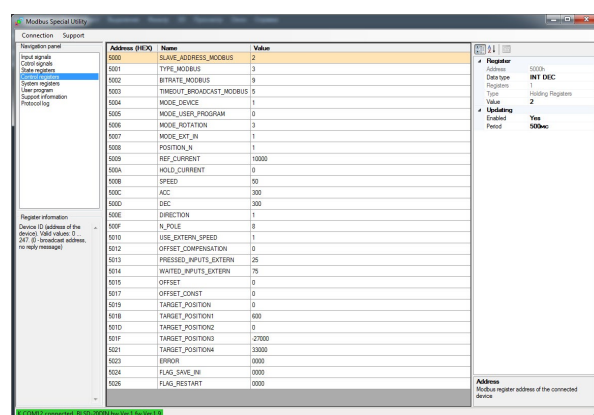

Address: Tallinn Science Park Tehnopol,
Akadeemia tee 21/6, 12618, Tallinn, Estonia
Phone: +372 6559914
E-mail: sale@smd.ee



SMART MOTOR DEVICES
DRIVERS AND CONTROLLERS FOR ELECTROMOTORS