



SMART MOTOR DEVICES

<https://www.smd.ee>

STEPPER MOTOR DRIVERS
SMD series
Open frame and carrier kit versions

manual
SMD.OFV.CKV.001



1. Product designation

The SMD series stepper motor driver is an electronic device designed to control a hybrid stepper motor. Drivers are available in four versions, differing in the maximum current per phase. All four versions are available as an open board device without housing (open frame version) or as a board in an open housing with DIN clamp (carrier kit version).

An example of designation when ordering a driver as an open board device without housing with a maximum motor phase current 2.8 A: "SMD-2.8 open frame version".

An example of designation when ordering a driver as a board in an open housing with DIN clamp with a maximum motor phase current of 1.6 A: "SMD-1.6 carrier kit version".

2. Technical specifications

Table 1. Specifications of SMD series drivers.

General characteristics:	SMD-1.6	SMD-2.8	SMD-4.2	SMD-8.0
Maximum current per phase, A	1.6	2.8	4.2	8.0
Minimum current per phase, A	0.1	1.3	2.7	5.0
Phase current setting resolution, A	0.1			0.2
Microstepping	1/1, 1/2, 1/4, 1/8, 1/16, 1/32, 1/64, 1/128		1/1, 1/2, 1/4, 1/8, 1/16, 1/32, 1/64, 1/128, 1/256	
Supply voltage, VDC, stabilized	12 - 24		12 - 48	
Control methods	External analog voltage signal; Logic signals «STEP», «DIR»; Built-in potentiometer*			
Parameters of inputs «STEP», «DIR», «EN», «SPD»				
High-level signal voltage range, VDC	5 - 12**			
Low-level signal voltage range, VDC	0-1			
Min input impedance of STEP, DIR, EN inputs, kOhm	100			
Max. current of control signals STEP, DIR, EN, mA	0.5			
Max. frequency of STEP control signal, kHz	200			
SPD control signal voltage range, VDC	0.1-10			
Min. input impedance of SPD input, kOhm	20		30	
Max. current of control signal SPD, mA	1			
Built-in oscillator frequency, kHz	0.1-10			

* Speed deviation when controlled by the built-in potentiometer max. 20%

** It is allowed to use a high level voltage signal 24V under condition of connecting current-limiting resistors of 1 kOhm for STEP, DIR, EN inputs.

Attention: When operate with a high inertia load, there is a possibility of turning the motor shaft during its sudden braking. In this case, as well as when the shaft is forced to rotate, the motor will induce an EMF, which can damage the output stages of the driver. To avoid such situations, it is necessary to avoid sudden braking of the motor, its forced rotation, as well as disconnection of the motor phases or turning off the power supply of during operation.



3. Control methods

The driver is controlled by the logical signals "EN" (ENABLE), "STEP" (STEP) and "DIR" (DIRECTION) or an analog signal. The control mode is selected by setting the D/A (digital/analog) jumper to the appropriate position. Position D (digital) activates the logic signal control mode, in which the rotation of the motor rotor by one step or part of a step is carried out along the front of the STEP signal in the direction specified by the DIRECTION signal. Input "EN" is inverted. Position A (analog) activates speed control mode with built-in potentiometer or analog voltage signal. The control method in this mode is determined by the position of the INT/EXT (internal/external) jumper. INT (internal) is used when controlling motor speed with the built-in potentiometer; EXT (external) - when controlling motor speed with an external analog signal 0-10V. The connection diagram of control signals is shown in the section 4 in fig. 2a and 2b.

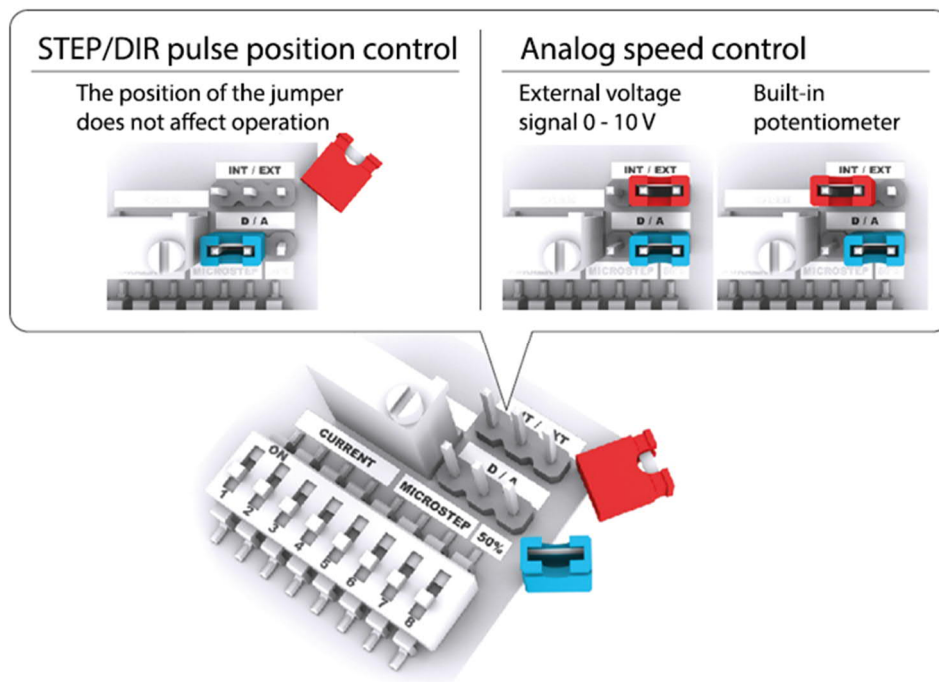

Fig.1. Position of jumpers for selecting mode and control method

Note: Mode switching and driver setting must be done with the power off.



4. Connection diagram

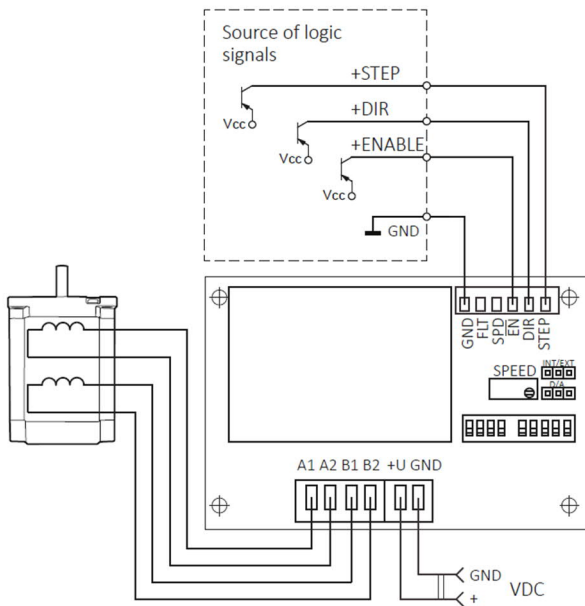

Fig.2a. SMD series driver wiring diagram for STEP/DIR/ENABLE logical signal control mode

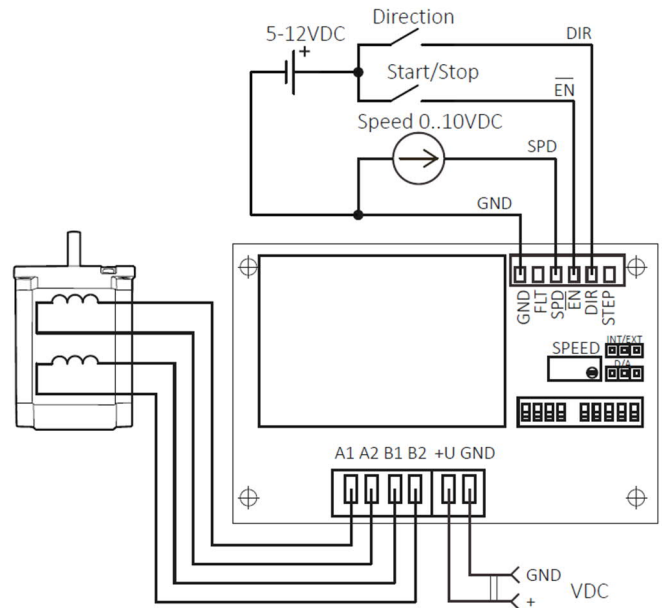

Fig.2b. SMD series driver wiring diagram for analog speed control mode

5. Dimensions

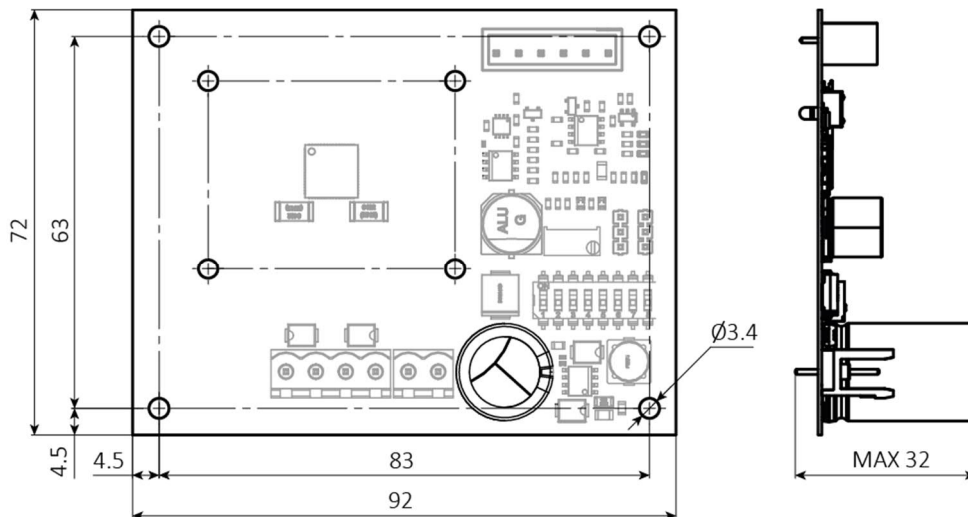

Fig. 3. Dimensions of stepper motor driver SMD-1.6 open frame version

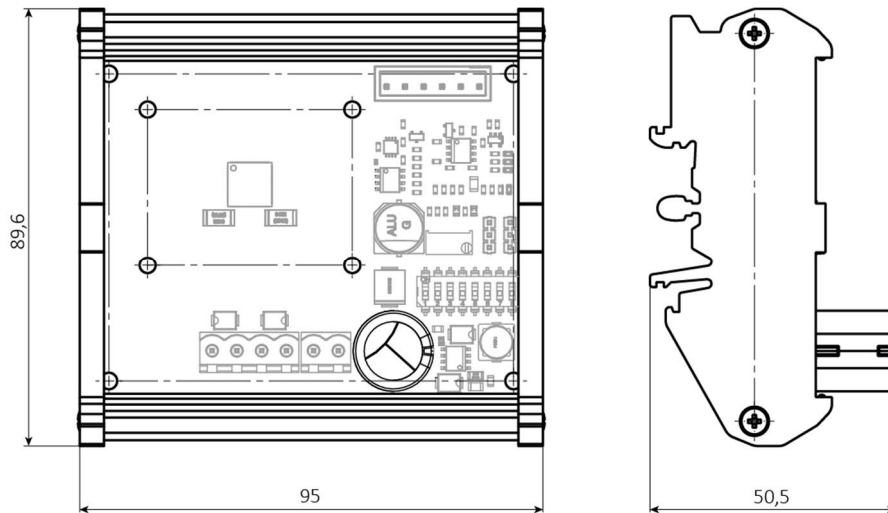

Fig. 4. Dimensions of stepper motor driver SMD-1.6 carrier kit version

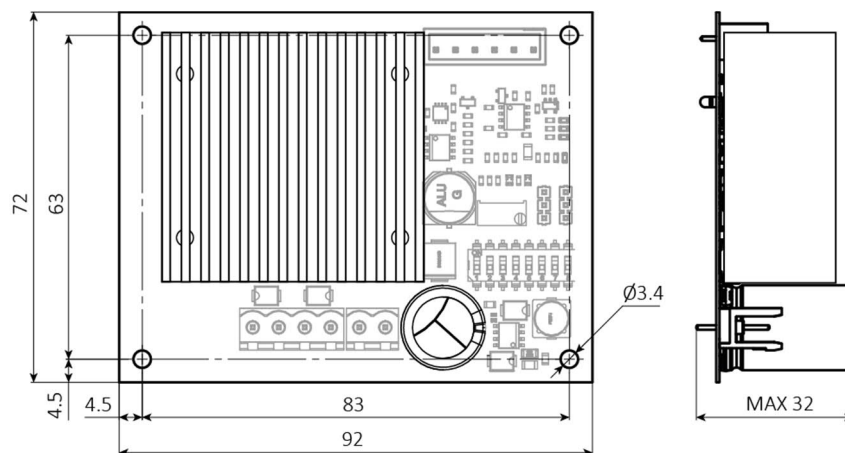

Fig. 5. Dimensions of stepper motor driver SMD-2.8 open frame version

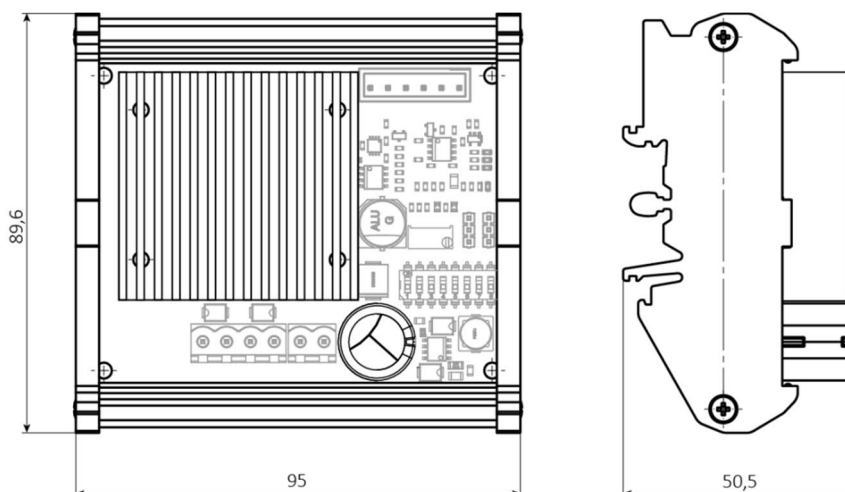

Fig. 6. Dimensions of stepper motor driver SMD-2.8 carrier kit version

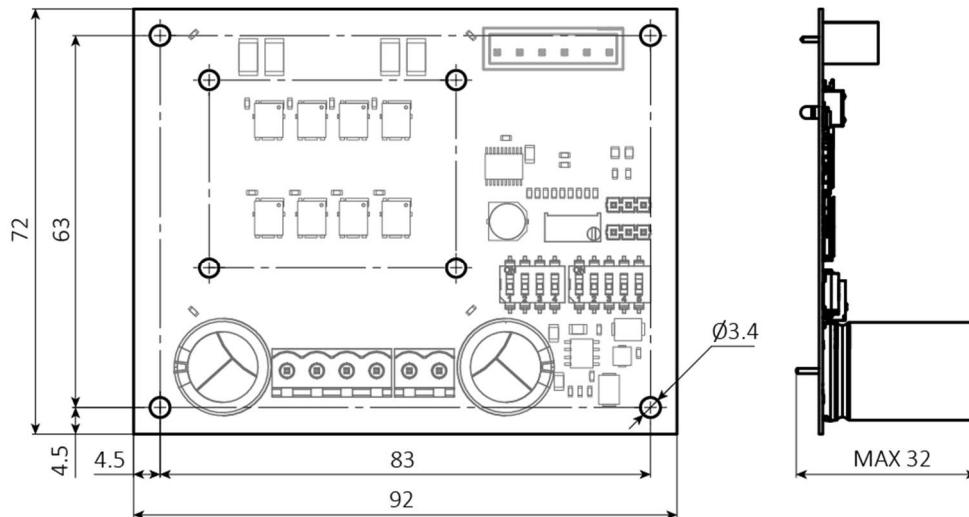

Fig. 7. Dimensions of stepper motor driver SMD-4.2 open frame version

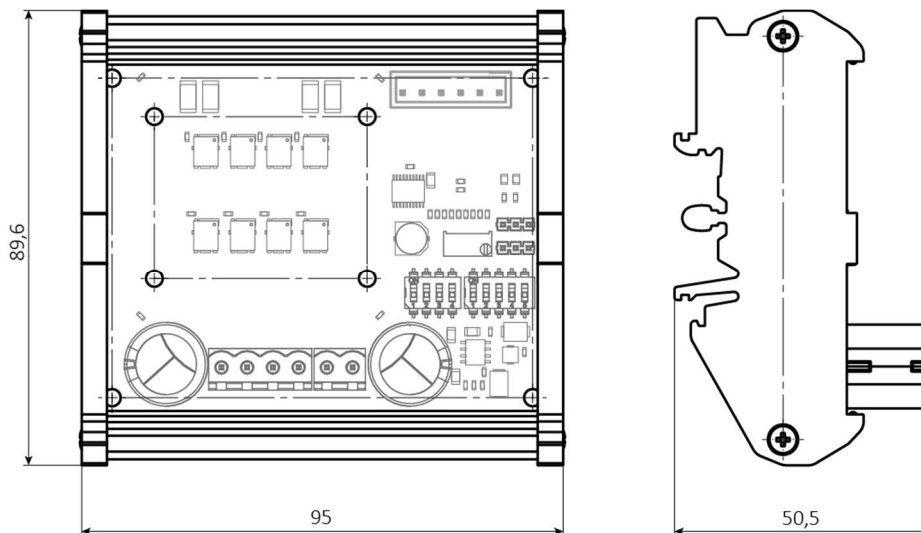

Fig. 8. Dimensions of stepper motor driver SMD-4.2 carrier kit version

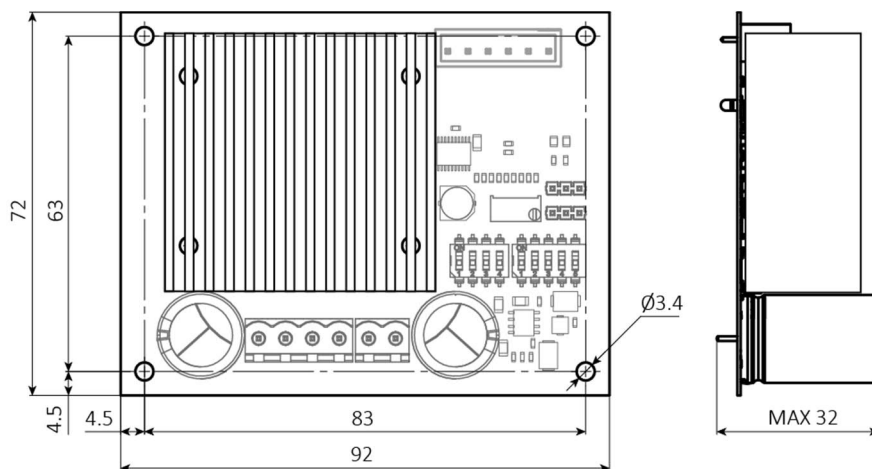

Fig. 9. Dimensions of stepper motor driver SMD-8.0 open frame version

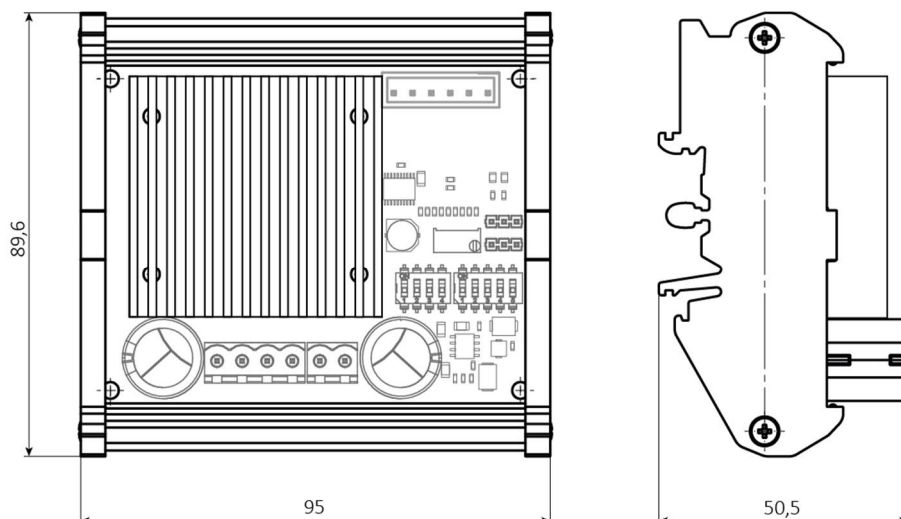

Fig. 10. Dimensions of stepper motor driver SMD-8.0 carrier kit version

6. Driver settings

To set the maximum motor phases current and microstepping mode set microswitches SW1 – SW8 according to the tables 2, 3 and 4.

Table 2. Setting maximum current per phase (microswitches CURRENT).

SW1	SW2	SW3	SW4	SMD-1.6	SMD-2.8	SMD-4.2	SMD-8.0
Microswitch position				Current, A			
OFF	OFF	OFF	OFF	0.1	1.3	2.7	5
OFF	OFF	OFF	ON	0.2	1.4	2.8	5,2
OFF	OFF	ON	OFF	0.3	1.5	2.9	5,4
OFF	OFF	ON	ON	0.4	1.6	3	5,6
OFF	ON	OFF	OFF	0.5	1.7	3.1	5,8
OFF	ON	OFF	ON	0.6	1.8	3.2	6
OFF	ON	ON	OFF	0.7	1.9	3.3	6,2
OFF	ON	ON	ON	0.8	2	3.4	6,4
ON	OFF	OFF	OFF	0.9	2.1	3.5	6,6
ON	OFF	OFF	ON	1	2.2	3.6	6,8
ON	OFF	ON	OFF	1.1	2.3	3.7	7
ON	OFF	ON	ON	1.2	2.4	3.8	7,2
ON	ON	OFF	OFF	1.3	2.5	3.9	7,4
ON	ON	OFF	ON	1.4	2.6	4	7,6
ON	ON	ON	OFF	1.5	2.7	4.1	7,8
ON	ON	ON	ON	1.6	2.8	4.2	8



Table 3. Setting microstepping mode (microswitches MICROSTEP).

SMD-1.6, SMD-2.8			
SW5	SW6	SW7	Microstepping
OFF	OFF	OFF	1/1
ON	OFF	OFF	1/2
OFF	ON	OFF	1/4
ON	ON	OFF	1/8
OFF	OFF	ON	1/16
ON	OFF	ON	1/32
OFF	ON	ON	1/64
ON	ON	ON	1/128

SMD-4.2, SMD-8.0				
SW1	SW2	SW3	SW4	Microstepping
OFF	ON	OFF	OFF	1/1
ON	OFF	ON	ON	1/2
ON	OFF	ON	OFF	1/4
ON	OFF	OFF	ON	1/8
ON	OFF	OFF	OFF	1/16
OFF	OFF	ON	ON	1/32
OFF	OFF	ON	OFF	1/64
OFF	OFF	OFF	ON	1/128
OFF	OFF	OFF	OFF	1/256

Table 4. Setting holding current (microswitch 50%).

SMD-1.6, SMD-2.8	SMD-4.2, SMD-8.0	Holding current, %
SW8	SW5	
ON	ON	50
OFF	OFF	100

7. Faults control

The driver provides indication of normal operation and emergency situations. The green LED "PWR" is used to indicate the power supply of the unit. The output signal and the red "FLT" LED are used to indicate the following situations:

- 1) Chip overheating.
- 2) Motor phase loss.
- 3) Only for versions SMD-1.6 and SMD-2.8 open frame and carrier kit versions - the occurrence of BEMF (for example, when the motor is in a resonance zone, during forced rotation of the motor, acceleration and deceleration).

8. Manufacturer information

Smart Motor Devices adheres to the line of continuous development and reserves the right to make changes and improvements in the design and software of the product without prior notice.

The information contained in this manual is subject to change at any time and without prior notice.



9. Warranty

Any repair or modifications are performed by the manufacturer or an authorized company.

The manufacturer guarantees the failure-free operation of the controller for 12 months since date of sale when the operation conditions are satisfied.

The manufacturer sales department address:

Smart Motor Devices OÜ,

Tallinn Science Park Tehnopol, Akadeemia tee 21/6, 12618, Tallinn, Estonia.,

Phone: + 372 6559914,

e-mail: mail@smd.ee

url: <https://smd.ee>

Date of sale:

Last modified: 13 May 2024