



SMART MOTOR DEVICES

<https://www.smd.ee>

**DC brush motor controller
BMD-40DIN**

manual
BMD.40.DIN.002

2019



1. Product designation

Controller BMD-40DIN is an electronic device to operate and control DC brush motors with maximum voltage 24VDC and power under 960W. The controller is designed to control speed, direction, smooth start and stop of brush motors. BMD-40DIN provides the function of precise adjustable motor overcurrent protection.

2. Technical characteristics

Power supply: 12...24VDC, stabilized;

Max. operation motor current: 40A;

Maximum voltage across a motor: $0.99 \cdot U_{sup}$;

Minimum non-zero voltage across a motor: $0.01 \cdot U_{sup}$;

Overcurrent protection:

- hardware short-circuit protection - 100A, 15 μ s;
- motor phase current limit – set by customer, limitation range 1.0 – 40 A, actuation time – 5 sec. Refer to the section 5 for instruction on motor overcurrent protection setting.

Protection of an actuating mechanism:

- emergency stop (HARD_STOP) - the motor stops immediately in case the protection circuit is broken.

Thermal protection:

- output stage temperature rise;
- brake circuit temperature rise.

Speed regulation:

- analog voltage signal: 0...5VDC;
- external potentiometer 2.2 kOhm;
- built-in potentiometer.

Input signals "DIRECTION" and "START/STOP" parameters:

- type - clean contact;
- max. current: 0,5 mA.

Environmental conditions:

- Ambient environment: non- corrosive, non-explosive,
- Humidity: 90% RH or less upon condition +25°C
- Condensation and freezing: none
- Pressure: 650...800 mm of mercury.
- Ambient Temperature: 0...+50°C

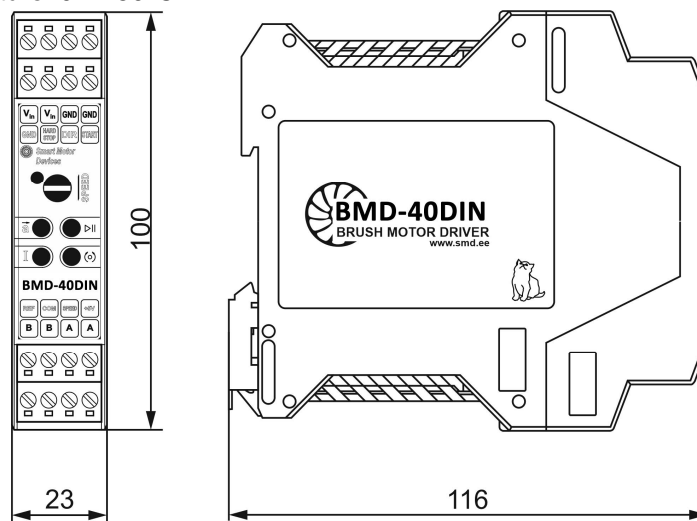

Fig.1 Dimensions of BMD-40DIN



3. Construction and control elements

BMD-40DIN is designed as a circuit plate with electronics elements, installed on a plate and covered with a plastic case. Besides electronic components, there are indicating and control elements and connection terminals on the board:

- terminal screws for power supply, motor windings and control circuit connection;
- "START/STOP" and "REVERSE" buttons;
- Internal preset potentiometers to adjust motor speed "SPEED", acceleration/deceleration "a" and motor current limit "I".
- LED for indication of the controller status.

To adjust motor speed the internal potentiometer "SPEED" and the analog input for voltage signals 0..5V are provided. To adjust acceleration and reversing deceleration internal potentiometer "a" is provided. To change motor direction the input and the button "DIR" are intended. To start or stop motion the button and the input "START/STOP" are intended. Adjustment of the protection operation threshold 0.1 ... 20A is carried out by the "CURRENT ADJUST" potentiometer and the "Vref" terminal.

4. Operation principle

Regulation of speed and the direction of rotation of a DC brush motor is carried out by change of voltage value and polarity. This is achieved by including the motor in a bridge circuit on transistor switches controlled by the PWM method.

The PWM generator is based on a microcontroller. In addition to the PWM controller, the microcontroller performs the functions of measuring the values of the signal parameters at the control inputs, the positions of the regulators, calculating the speed, acceleration and braking according to the internal program.

5. Assembly and connection.

Please, learn this manual carefully before connection and assembly.

Please, wire just when power is off. Do not attempt to change wiring while the power is ON.

Please, provide a reliable contact in connection terminals. During wiring, please, observe the polarity and wire management.

IMPORTANT: due to high current it is strongly recommended to place a power supply in direct proximity to the controller BMD-40DIN. It is obligatory to use wire cross-section 3 mm² (AWG-8). The power supply must be able to provide the current 20% higher than a maximum possible current consumption while in operation. Recommended wire length: no longer than 100 cm for current up to 10A; no longer than 50 cm for current from 10A to 20A, no longer than 25 cm for current 20A to 40A.

The connection scheme is shown on figure 2.

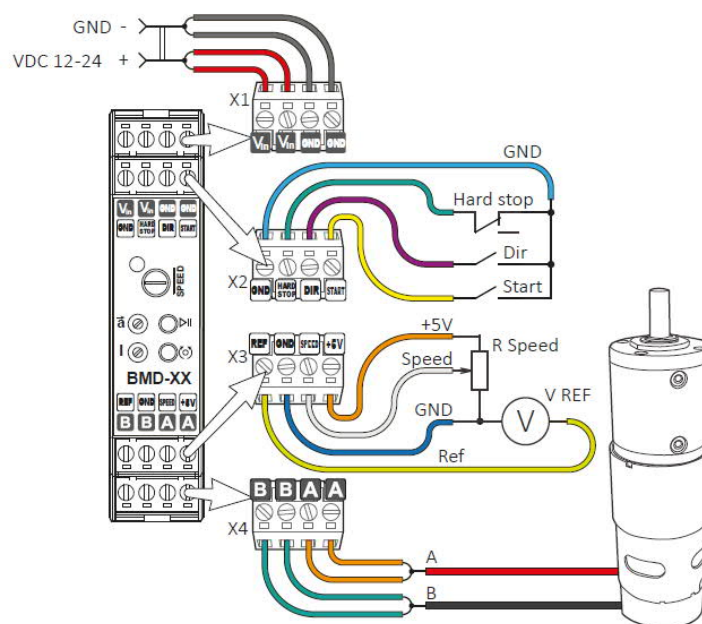

Fig.2. BMD-40DIN connection scheme (example of speed control by an external potentiometer.)



- 1) Make sure the power supply is turned off. Please, wire just when power is off.
- 2) Select input signals logic (refer to the section 7).
- 3) Connect the motor to the controller terminals A and B.
- 4) Connect the control elements to the controller according to chosen speed adjusting method:
 - Internal potentiometer - additional connection doesn't required
 - External potentiometer – connect potentiometer to the contacts “SPEED”, GND and “+5V”. The internal potentiometer “SPEED” should be turned to the end left position.
 - Analog signal 0...5 VDC – connect the source of analog signal 0...5VDC to the “SPEED” contacts: “-“ to the “GND” contact and “+” to the SPEED” contact. The motor speed is proportional to the signal voltage.
- 5) If needed, connect control elements to the “START/STOP” and “DIR” contacts. These inputs are clean contact.
- 6) Connect power supply to the controller contacts: “+” of the power supply to the terminal “V_{IN}”, “-“ of the power supply to the terminal “GND”. Wire cross-section should be suitable to the motor current consumption. We recommend using wire cross-section 3 mm² (AWG-8). Ground the power supply unit.
- 7) Set speed and acceleration regulators to the end CCW position, which correspond to their minimum values.
- 8) Using the potentiometer «CURRENT ADJUST», set the maximum motor current. Adjust the «CURRENT ADJUST» potentiometer and control the set current limit by a voltmeter, connected to «GND» and «V_{ref}» terminals (fig.3). The motor current limitation can be calculated as:
$$I_{lim} = 1.0 + 39.9 \times (V_{REF} / 3.3)$$

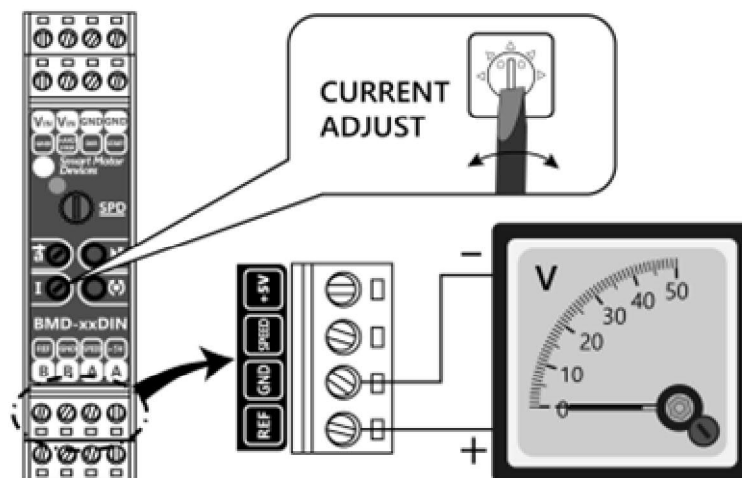

Fig. 3. Connection of a voltmeter for setting of a motor maximum current limit.

6. Motor Control

1. Choose the method of speed regulation: internal or external potentiometer or analog voltage signal 0-5VDC.
2. Connect the motor, power supply and control elements to the controller according section 5.
3. Turn on the power supply. The controller is ready for operation. LED at the front panel of the controller should solid light. Adjust the motor current limit (see the section 5).
4. Start the motor by button or input signal «START/STOP». The LED should start blinking (period 1 sec).
5. Adjust the motion parameters by using of a speed regulator, acceleration potentiometer and direction input or button.



In case of short-circuit of motor phases or overcurrent 100A for 15 μ s, the controller turns to an emergency mode, deenergizes the motor and indicates the alarm by LED blinking.

In case of motor current exceeds the set limit for 5 sec, the controller also turns to an emergency mode, red LED is blinking.

To reset the emergency mode, reset the power supply of the controller.

7. Input signals logic

The controller BMD-40DIN provides few options for processing of input signals START/STOP and DIR. Jumpers for selection of the necessary options are located on the electronic board under the case of the controller.

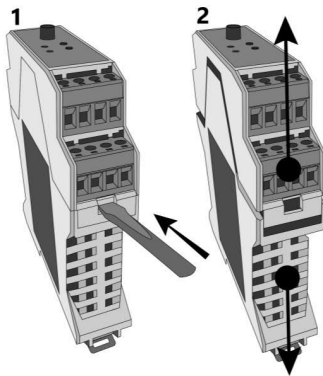
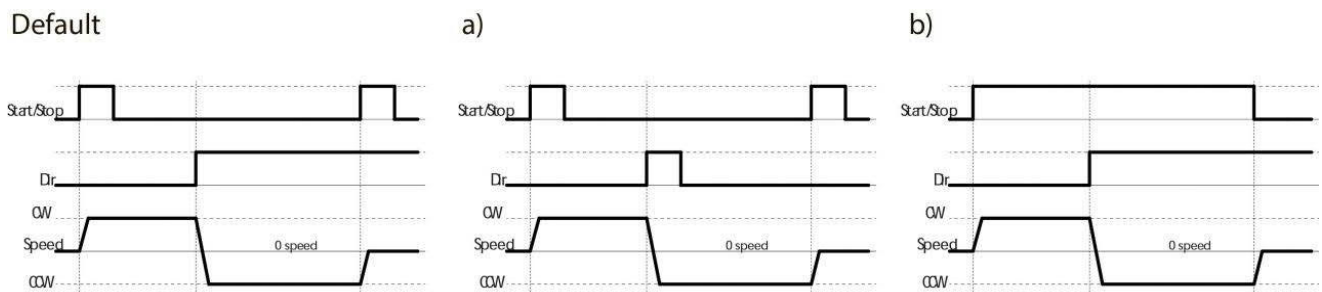

Fig. 4. Take off the case

To open the case:

- Turn off the power supply.
- Disconnect the terminals from the controller;
- Remove the controller from the DIN rail;
- Open the controller case as shown in the fig. 4:
 1. Press down on the latch with a flathead screwdriver on both sides;
 2. Pull the top and bottom of the case apart;
- Set the jumpers to the required position

As a default the controller is supplied with standard signal logic: input START/STOP is processed as per the front edge of the signal, input DIR is processed as per the signal level.



Operation logic of the inputs "START/STOP" and "DIR" can be adjusted with the jumpers "START_PIN" and "DIR_PIN" – fig. 5.

If the corresponding pair of contacts is closed by a jumper, their state corresponds to the "ON" value. If the jumper doesn't close the contacts, the state of the contacts corresponds to the value "OFF".



The logic of operation of the control inputs "START/STOP" and "DIR" is shown in the figure 6.



Fig. 5. START_PIN and DIR_PIN jumpers

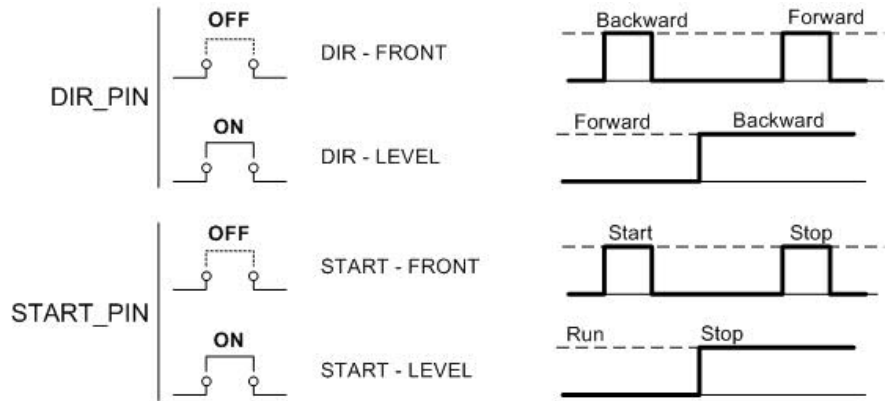

Fig. 6. Operation logic of input signals

8. Alarms indication

LED on the front panel of the controller indicates the controller operation status. In case of normal operation the indicator is green. Green indicator blinks during motor operation (approx. 1 time per second). In case if errors occur, the LED indicates the code of an error. The number of red blinks represents the alarm code (refer to the table below).

LED errors indication

Alarm code	Alarm	Alarm code	Alarm
0	Normal operation	4	Internal power switches overheating
1	Out of voltage range of the internal converter	5	Wrong motor connection or emergency stop (HARD_STOP)
2	Short circuit in a motor phase	6	Testing version of firmware
3	Internal brake circuit overheating		

9. Delivery in complete sets

DC brush motor controller BMD-40DIN

1 pcs

10. Manufacturer information

Smart Motor Devices adheres to the line of continuous development and reserves the right to make changes and improvements in the design and software of the product without prior notice.

The information contained in this manual is subject to change at any time and without prior notice.

11. Warranty

Any repair or modifications are performed by the manufacturer or an authorized company.

The manufacturer guarantees the failure-free operation of the controller for 12 months since date of sale when the operation conditions are satisfied.

The manufacturer sales department address:

Smart Motor Devices OÜ,
Tallinn Science Park Tehnopol, Akadeemia tee 21/6, 12618, Tallinn, Estonia,
Phone: + 372 6559914,
e-mail: mail@smd.ee
url: <http://smd.ee>

Date of sale:

Last modified: 28.04.2023